

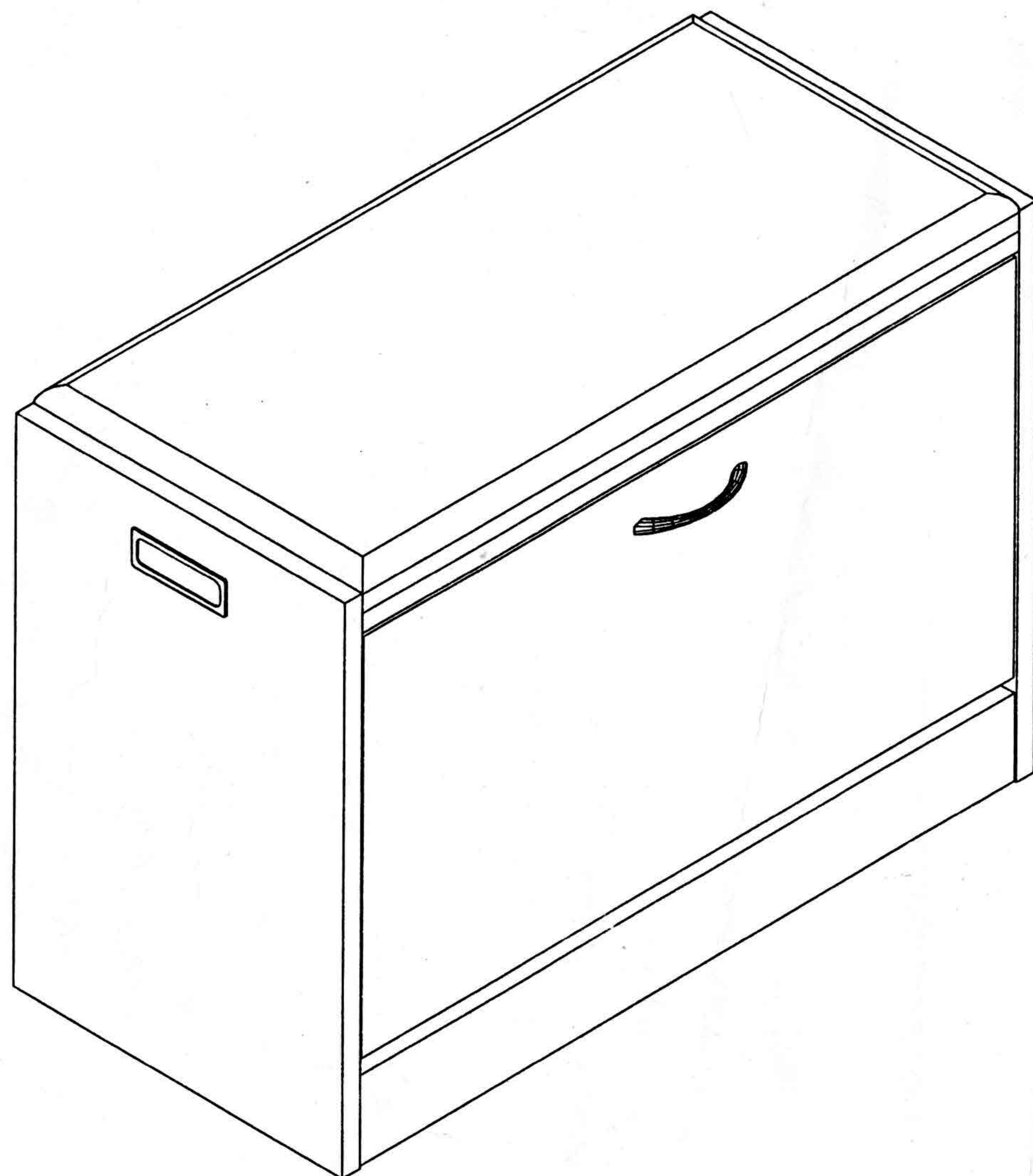









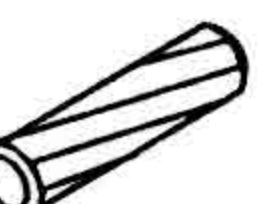

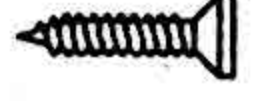
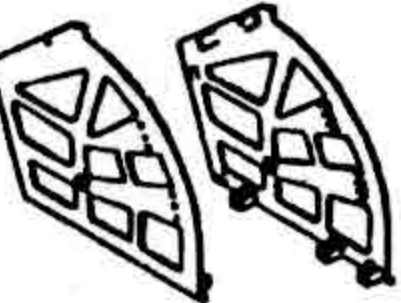

Assembly Instruction



HARDWARE LIST

<p>A</p>  <p>X12</p>	<p>B</p>  <p>X12</p>	<p>C</p>  <p>Ø8*40 X4</p>	<p>D</p>  <p>X1</p>
<p>E</p>  <p>Ø4*16 X2</p>	<p>F</p>  <p>X2</p>	<p>G</p>  <p>Ø4*8 X4</p>	<p>H</p>  <p>Ø4*14 X12</p>
<p>I</p>  <p>X1</p>	<p>J</p>  <p>X2</p>	<p>K</p>  <p>X2</p>	<p>L</p>  <p>X2</p>
<p>M</p>  <p>4*12 X2</p>	<p>N</p>  <p>X4</p>	<p>O</p>  <p>Ø3*14 X4</p>	<p>P</p>  <p>X4</p>
<p>Q</p>  <p>X4</p>			

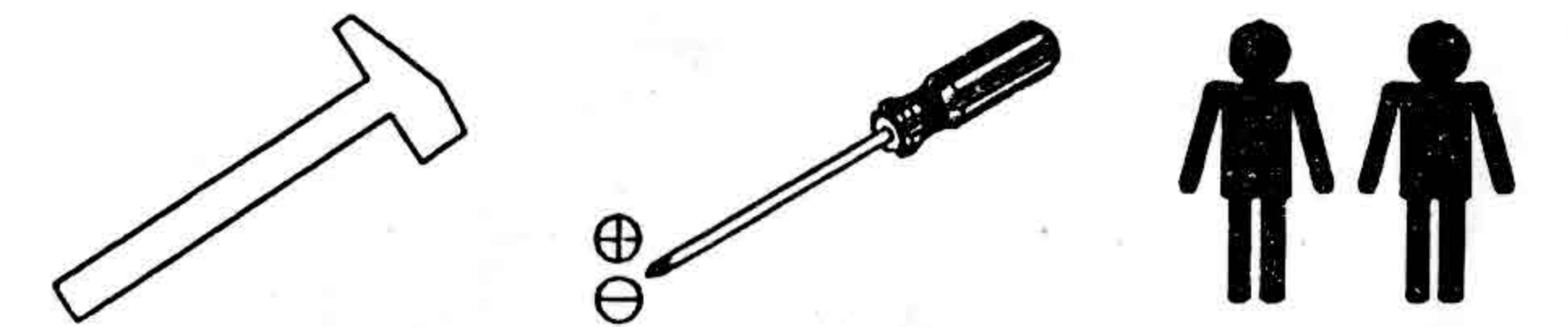

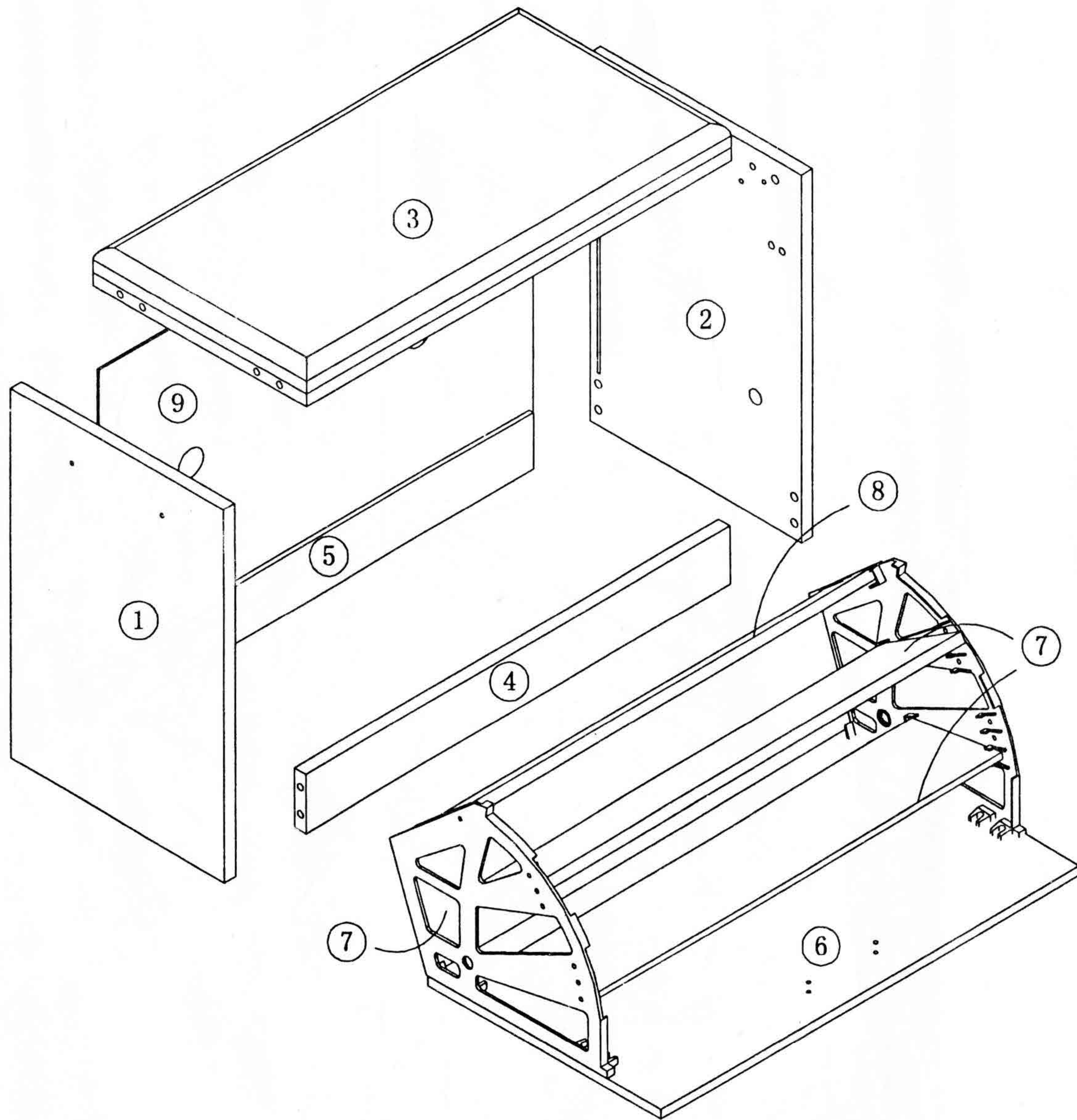

NO.	QTY.		
①	1		
②	1		
③	1		
④	1		
⑤	1		
⑥	1		
⑦	3		
⑧	1		
⑨	1		

1

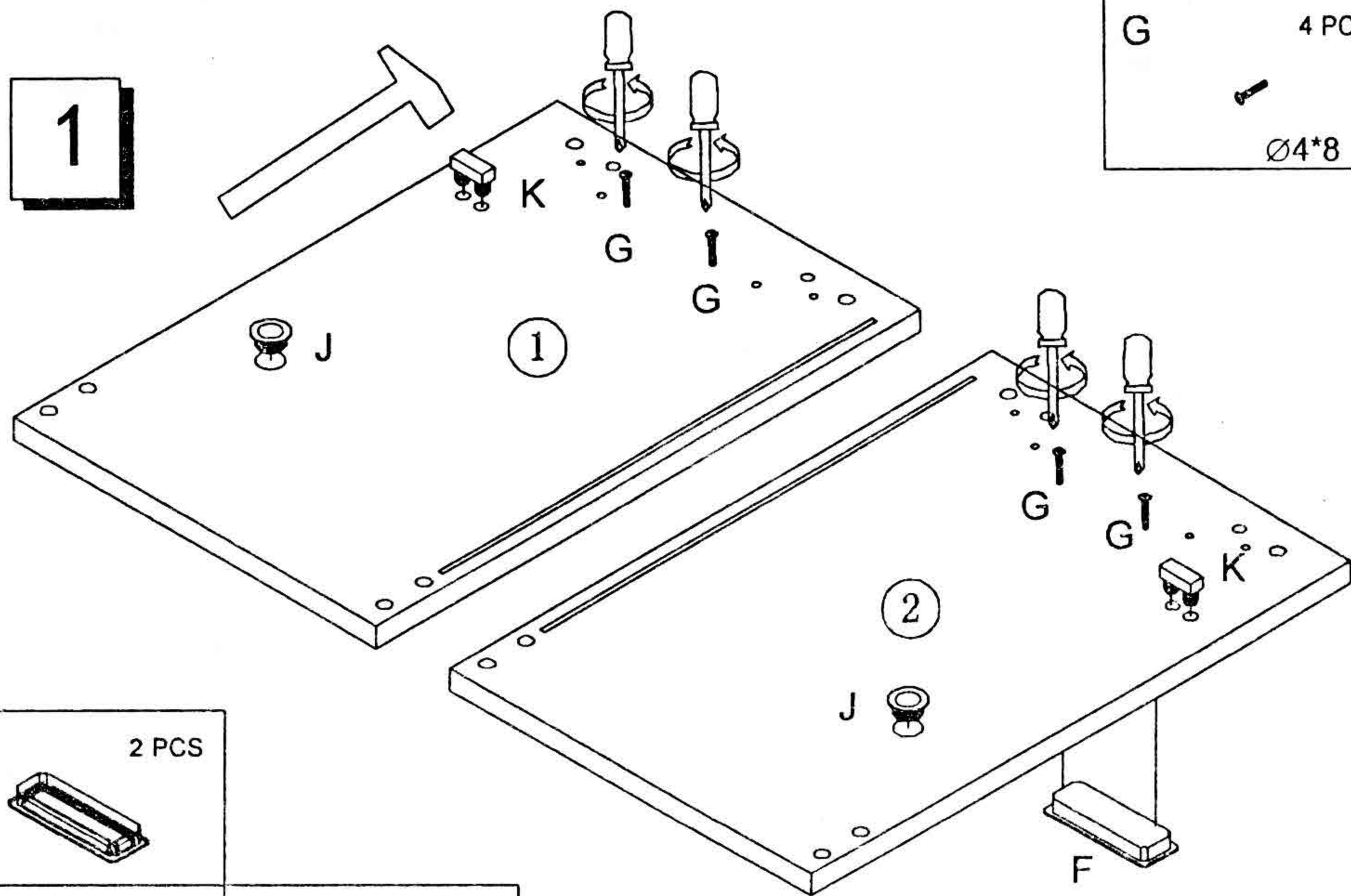

G 4 PCS
Ø4*8

2

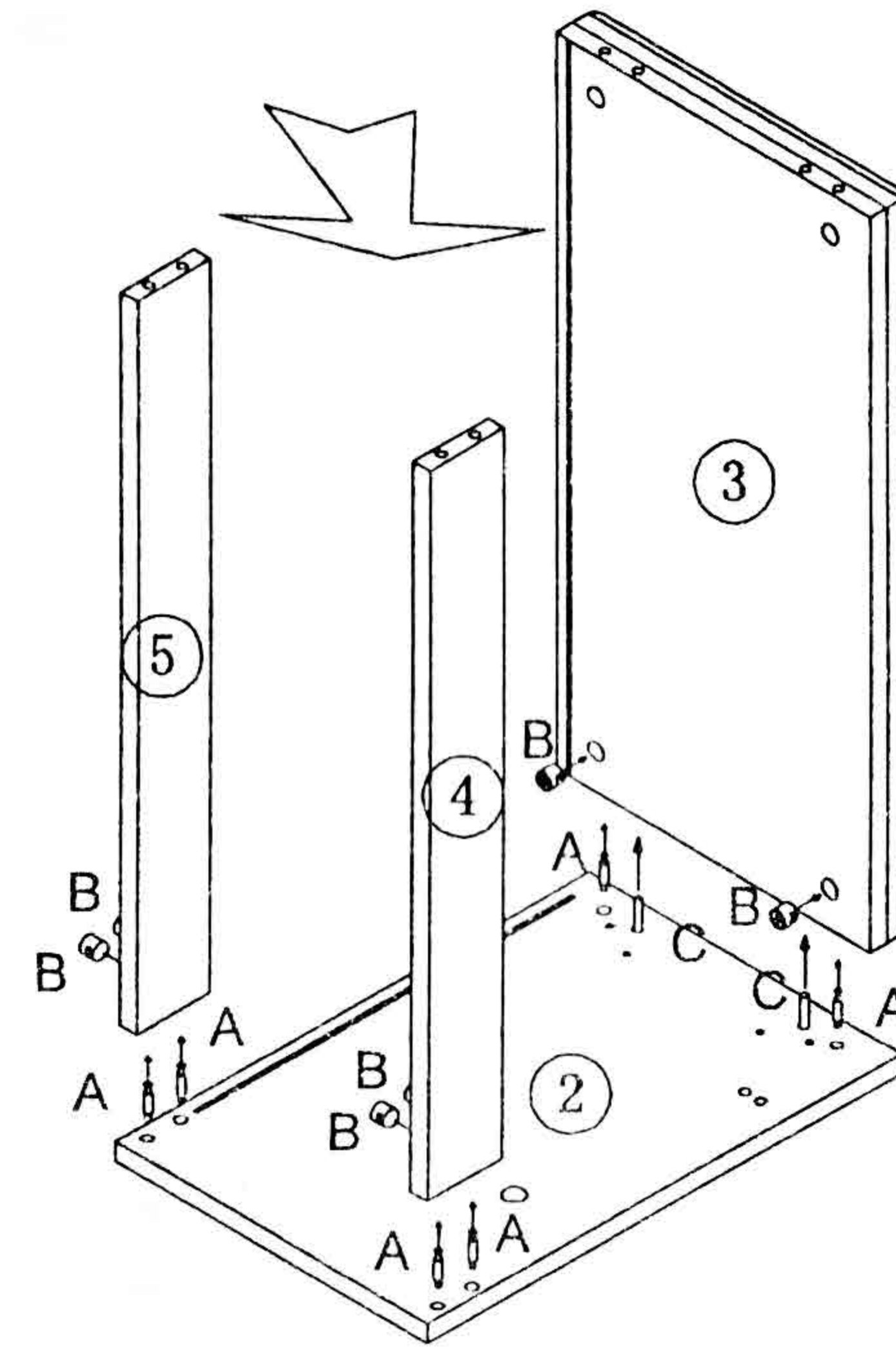

C 2 PCS
Ø8*40

B 6 PCS

A 6 PCS

F 2 PCS

J 2 PCS

K 2 PCS

3

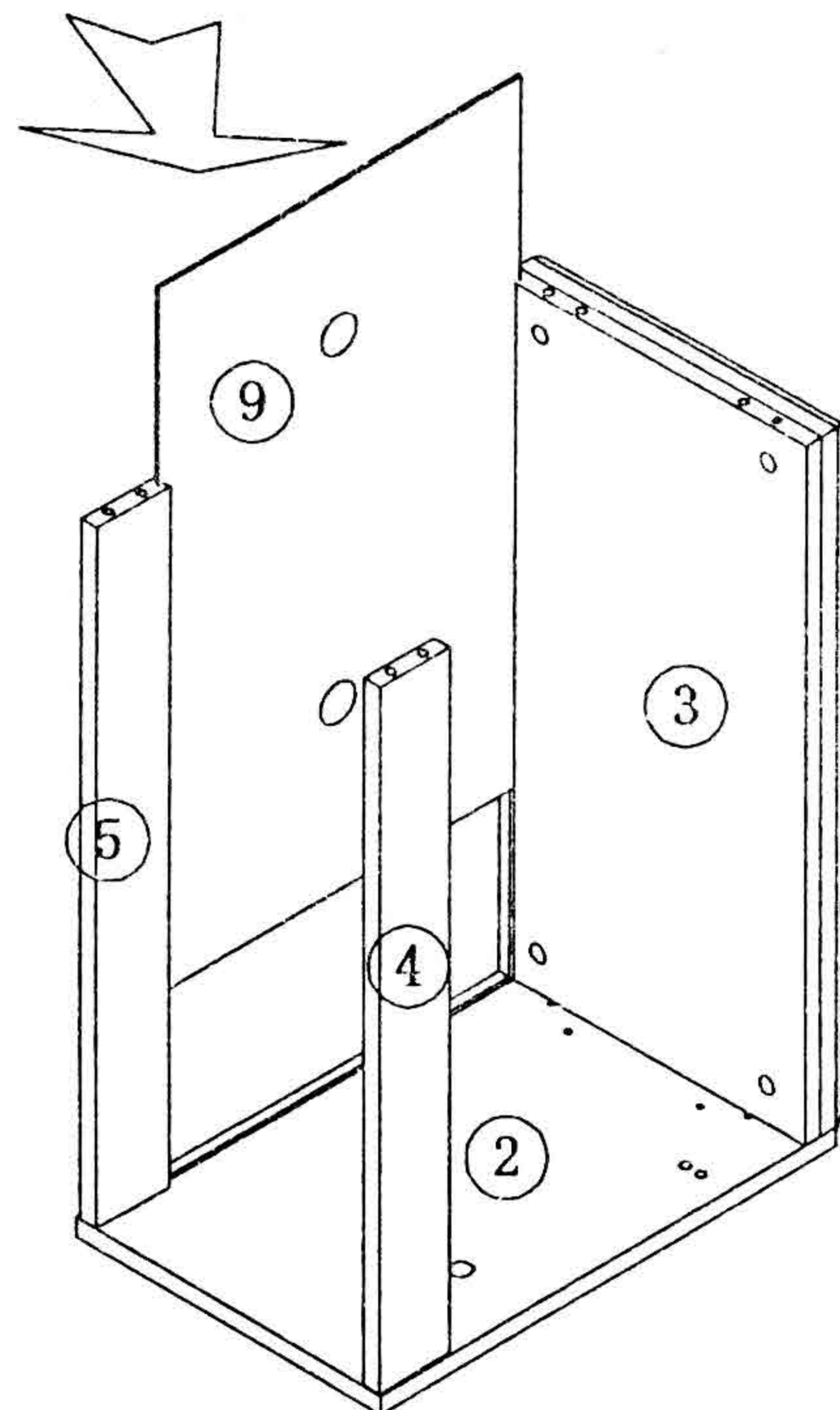

4

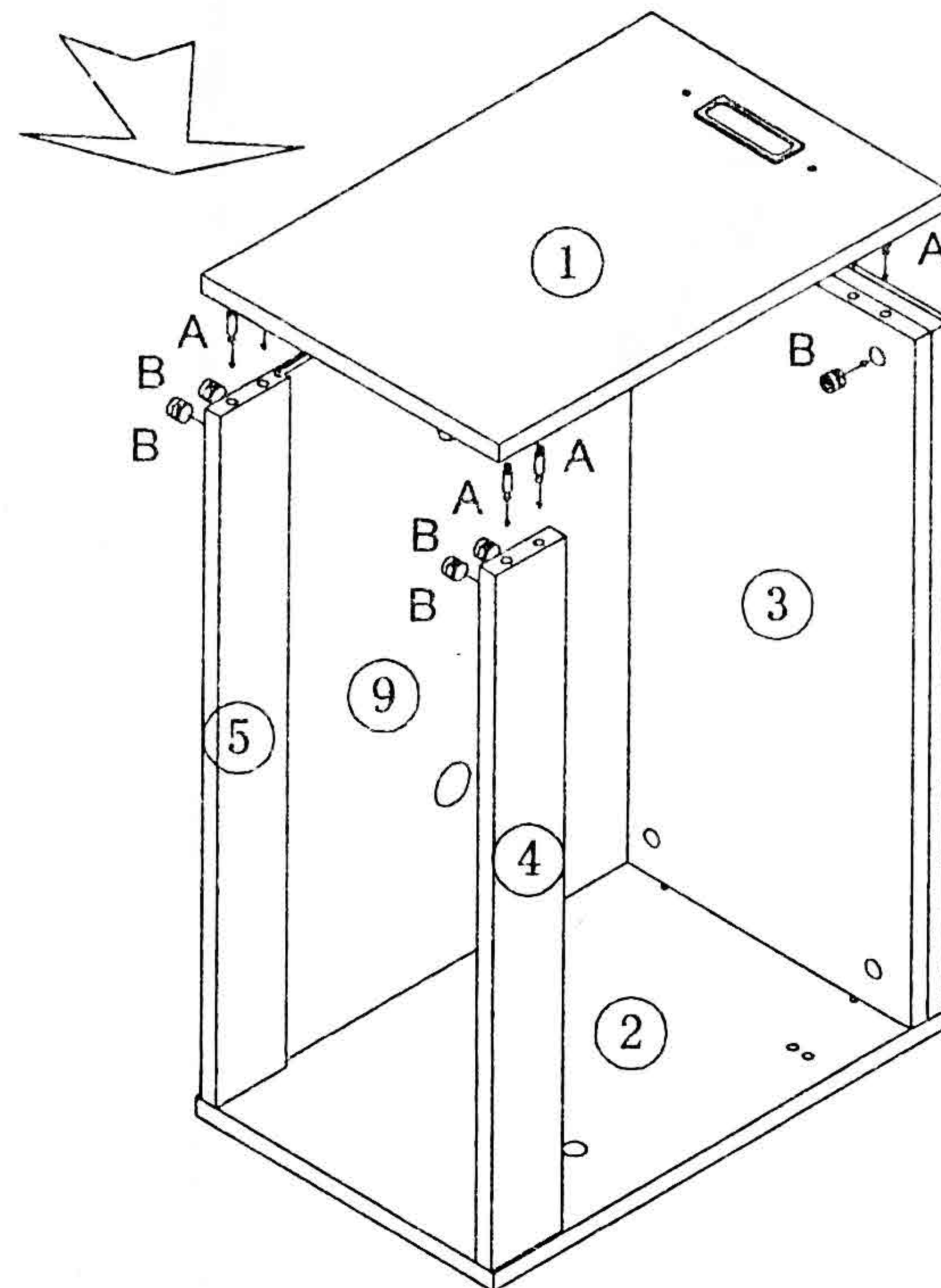

C 2 PCS
Ø8*40

B 6 PCS

A 6 PCS

5

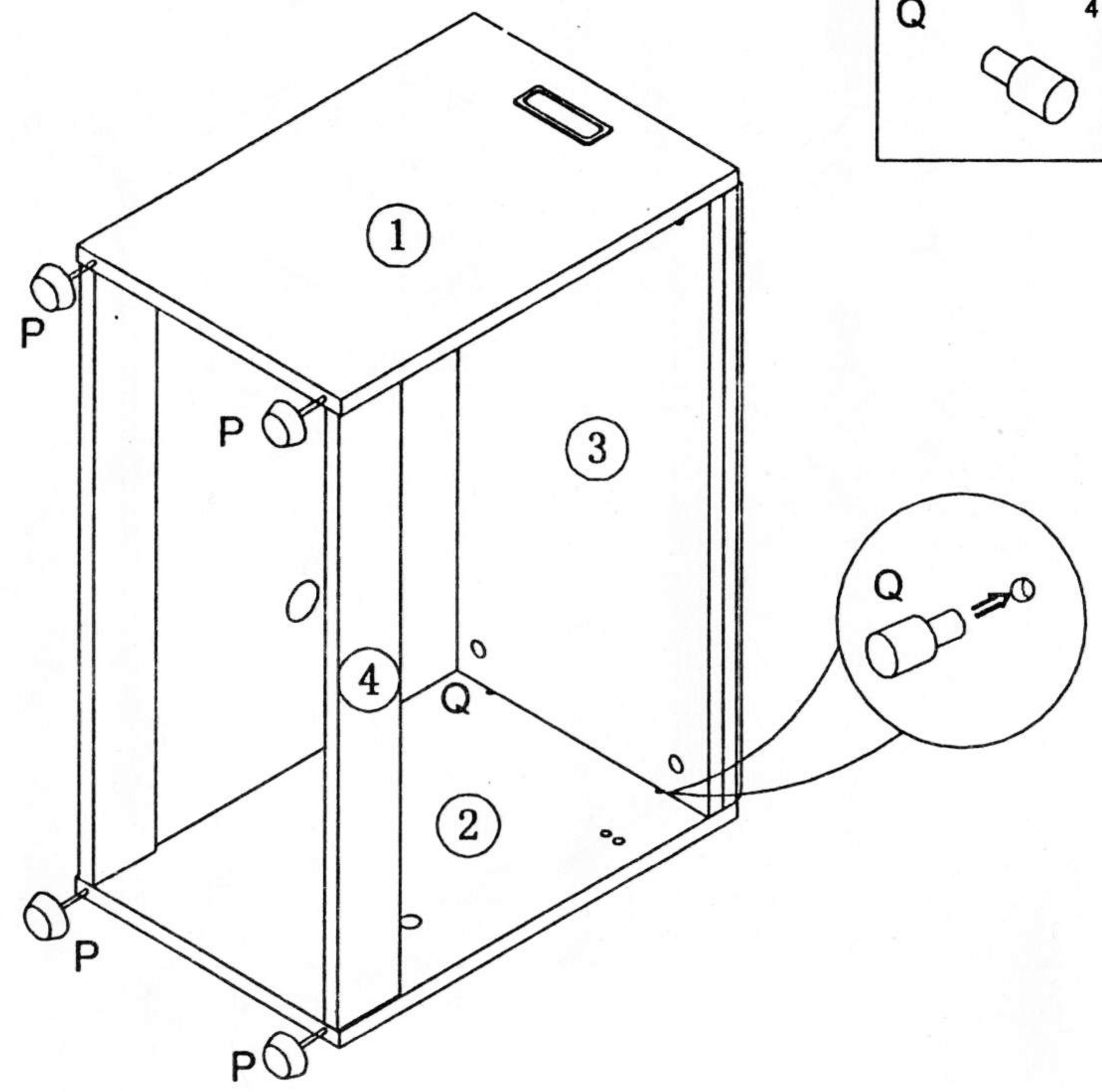

Q 4 PCS

P 4 PCS

7

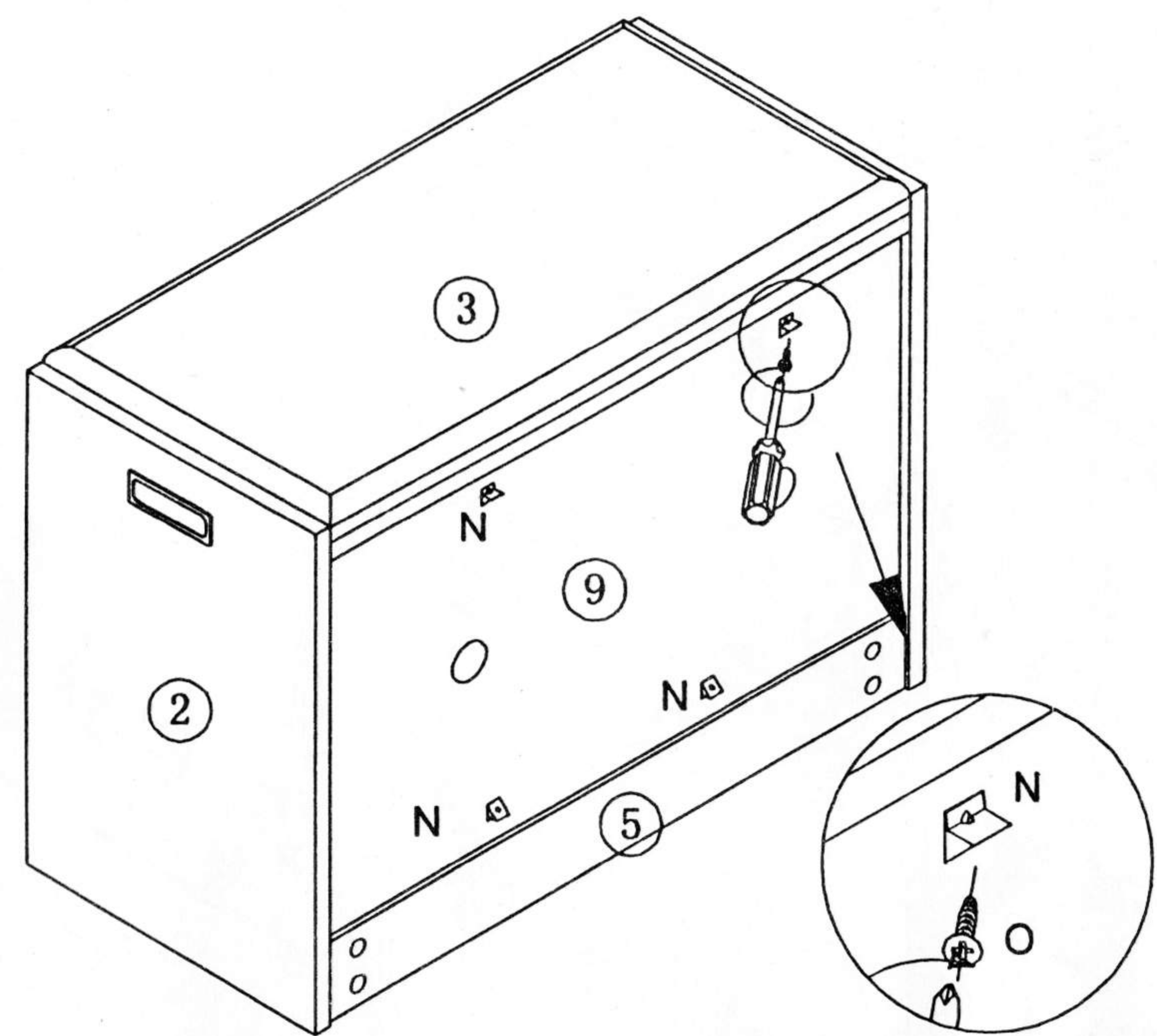

N 4 PCS

O 4 PCS
Ø3*14

6

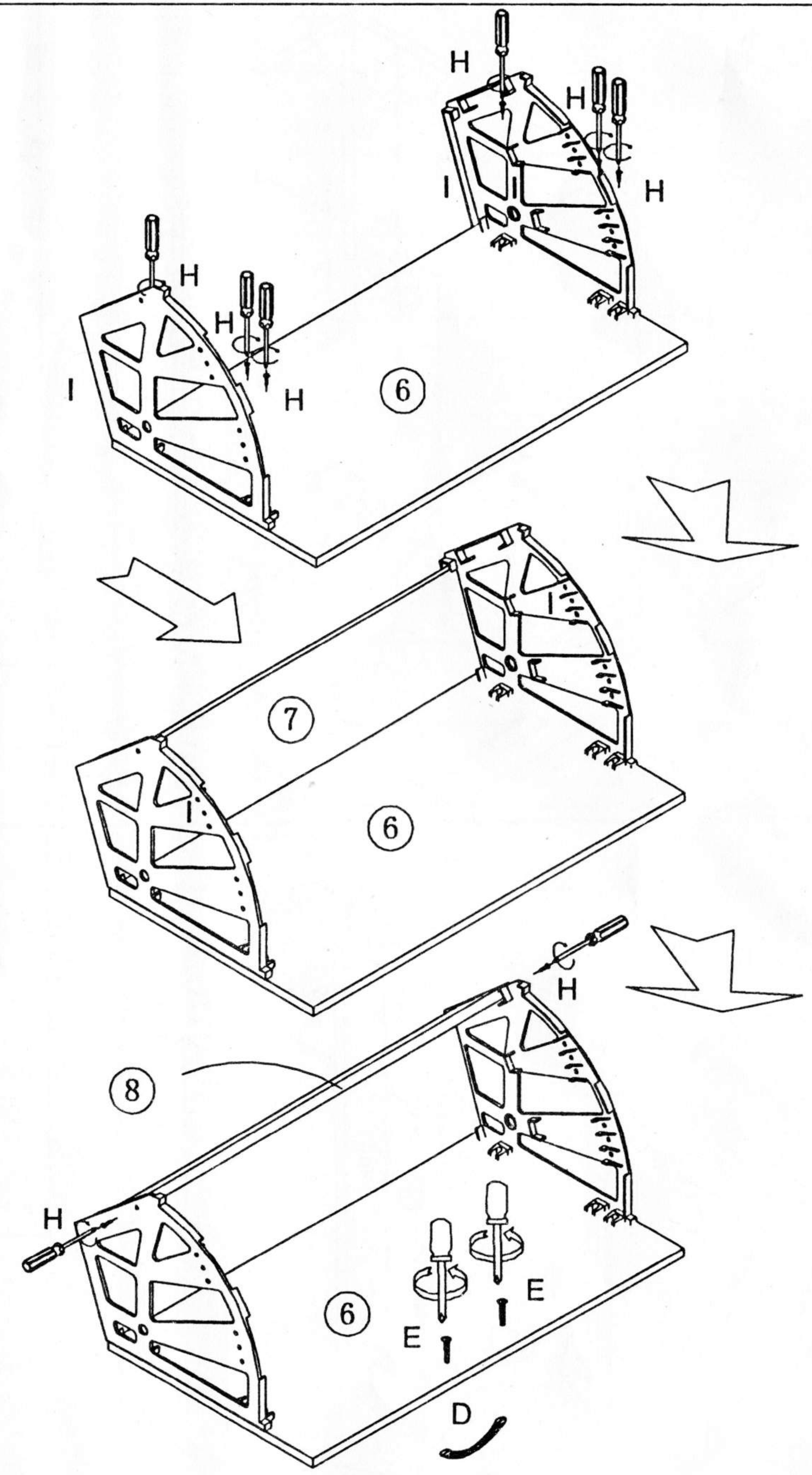

I 1 PCS



H 8 PCS
Ø4*14

D 1 PCS

E 2 PCS
Ø4*16

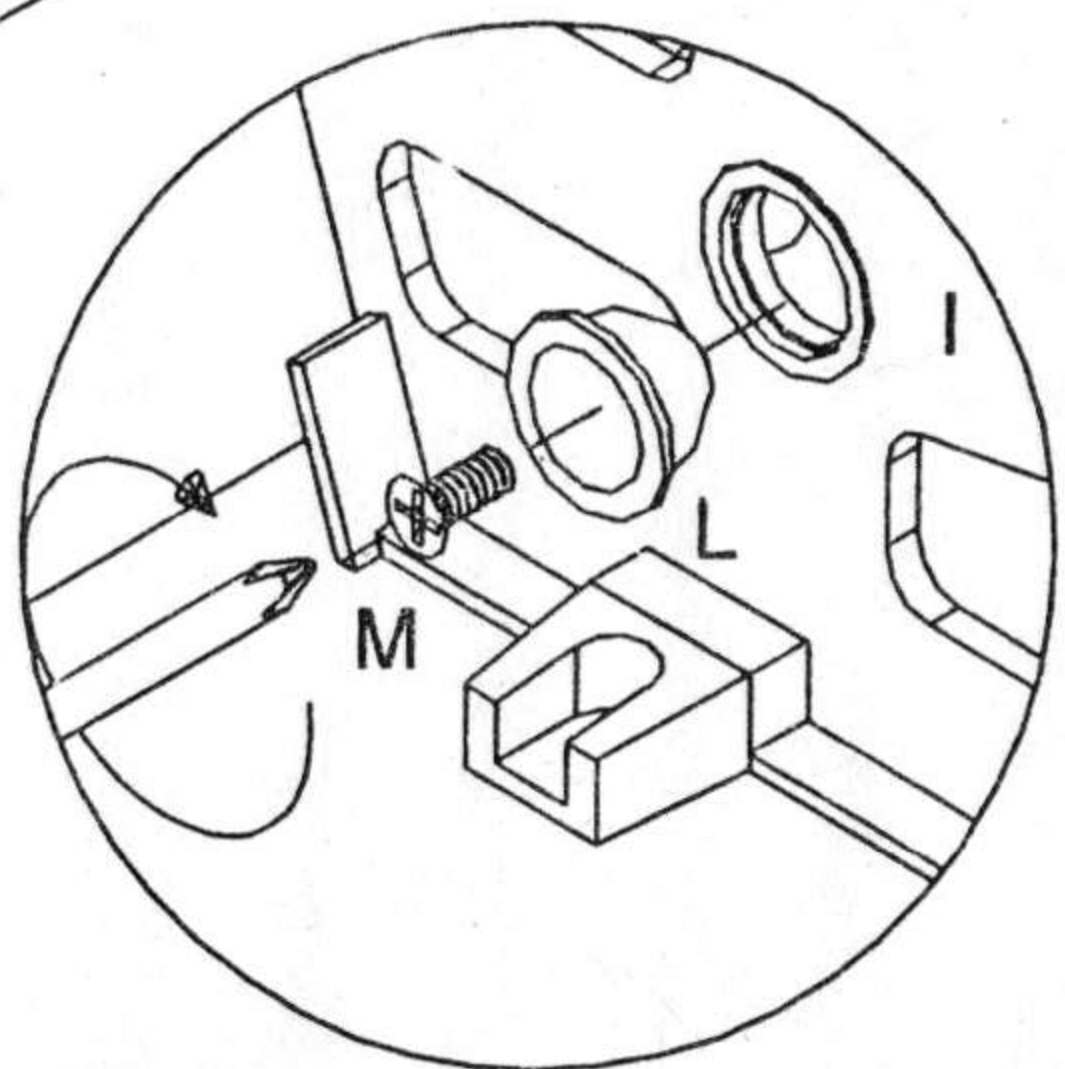
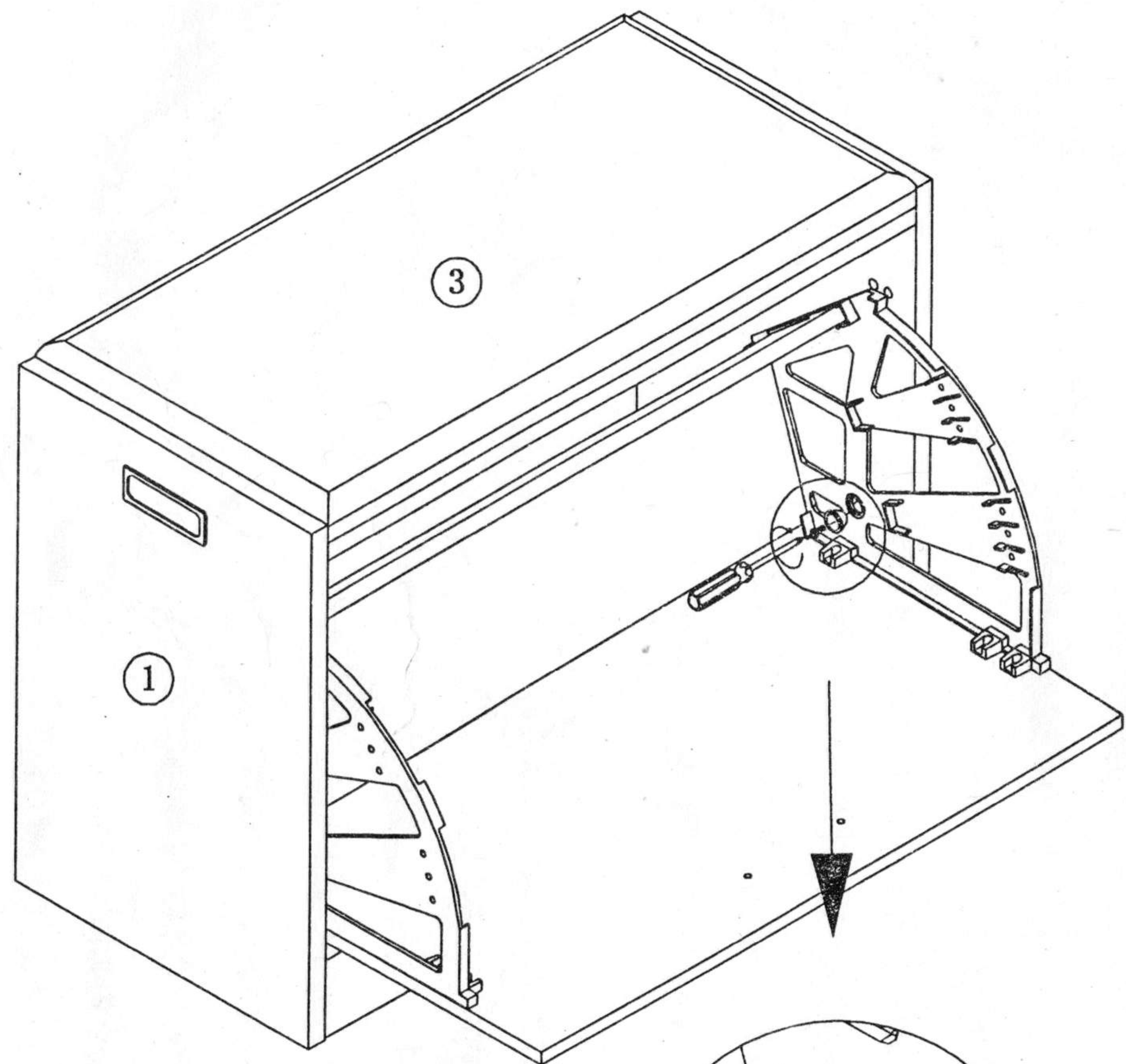
8



L	2 PCS	M	2 PCS
			

9

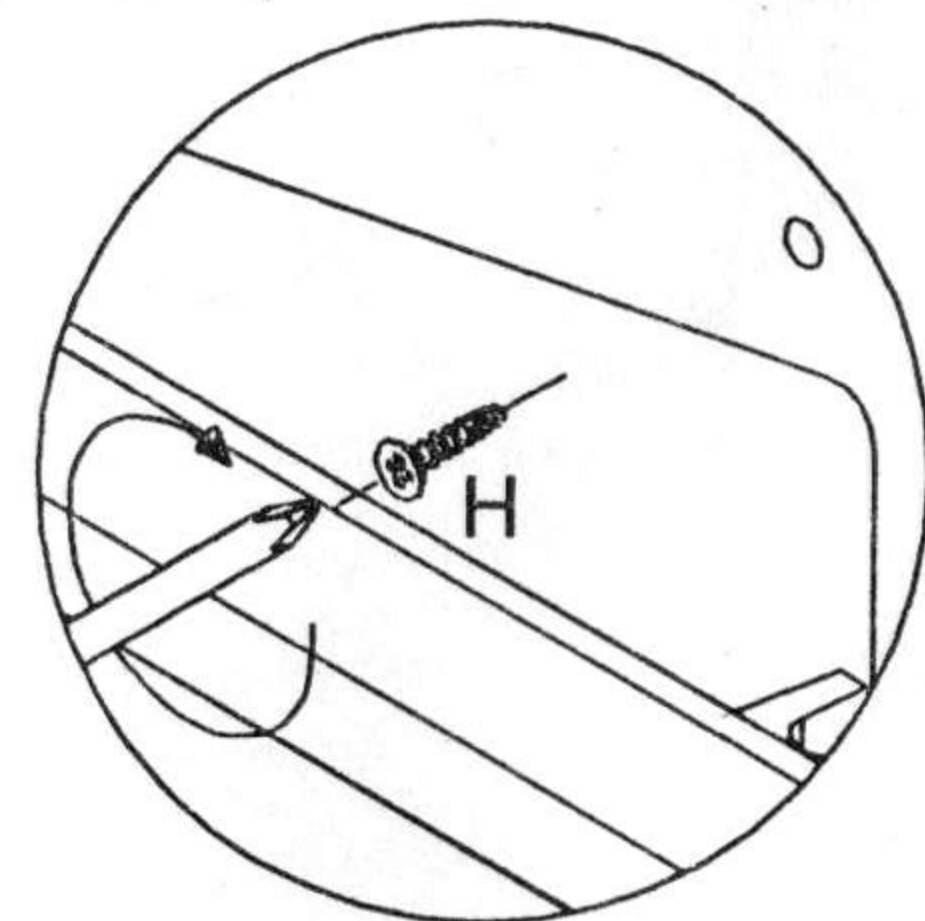
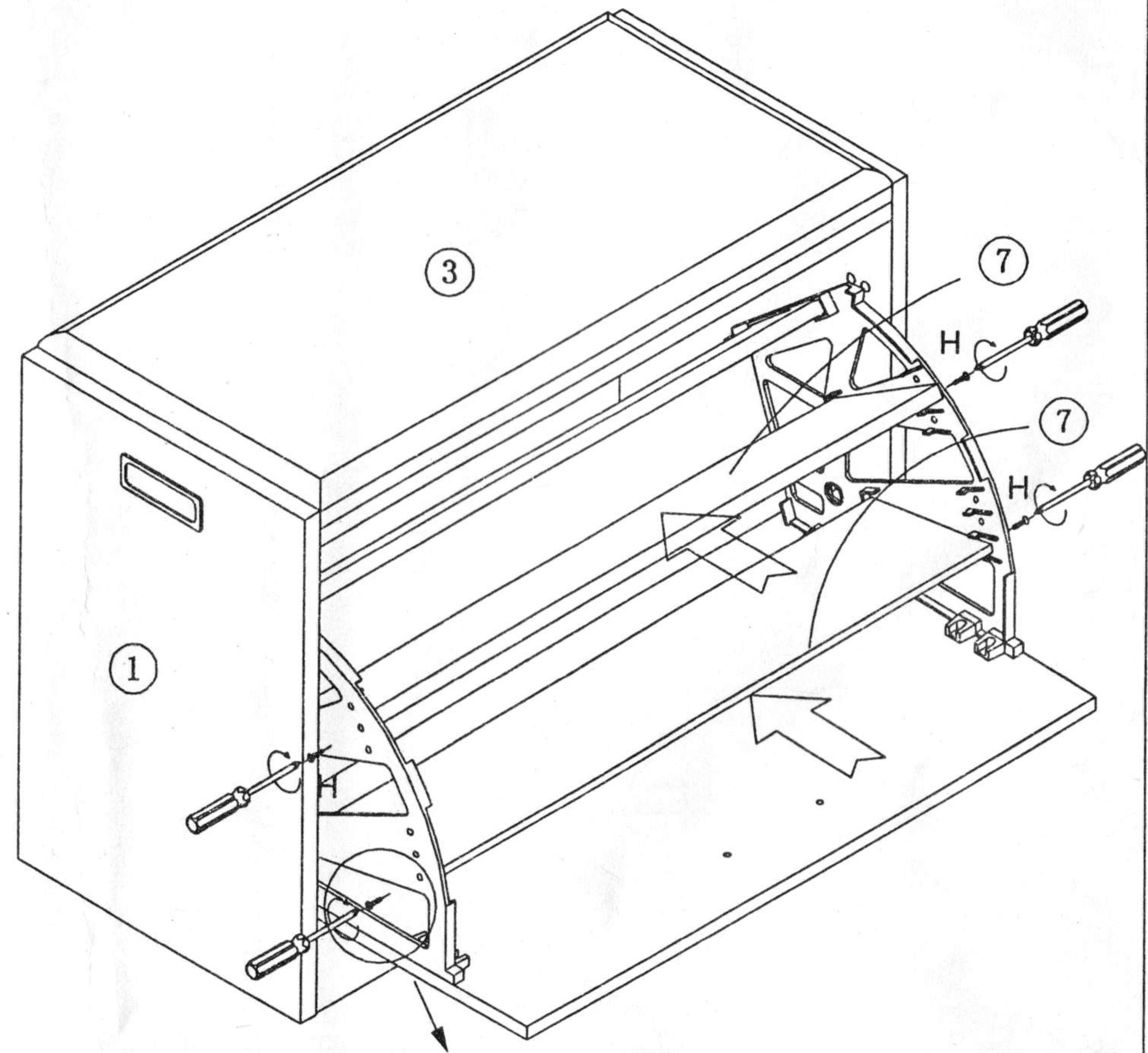

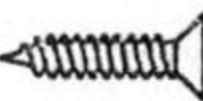
H	4 PCS
	
	Ø4*14